



VACUUM PACKAGING

ECONOMY VACUUM PACKAGING MACHINES

Item #: 24081 / 24082 / 24083 / 31824

Model: VP-CN-0971 / VP-CN-1220 / VP-CN-1060 / VP-CN-1273

Economy Vacuum Packaging Machines

These vacuum packaging machines are ideal for a variety of applications. The machines are equipped with a digital control panel that controls the sealing temperature, sealing time, drawing air time, and cooling time. Once the lid is closed, the machine automatically starts the sealing process.



24081
Model: VP-CN-0971



24082
Model: VP-CN-1220



24083
Model: VP-CN-1060



31824
Model: VP-CN-1273

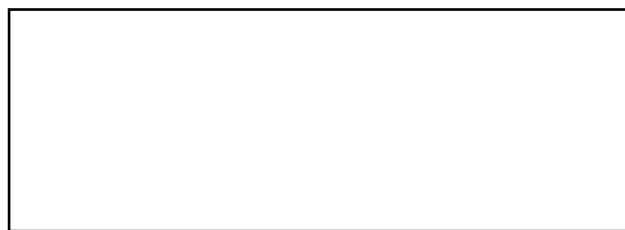

Authorized Dealer

VACUUM PACKAGING

ECONOMY VACUUM PACKAGING MACHINES

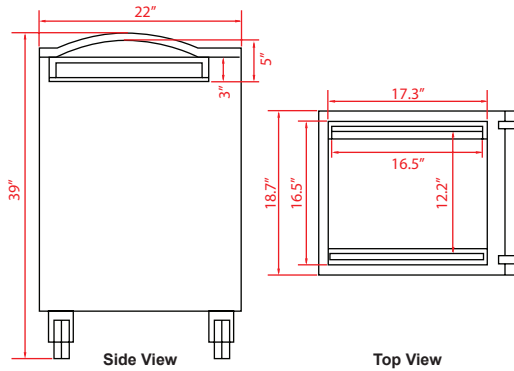

1.2HP and 16.5" Double Seal Bar - 17.3" x 16.5" x 3"

ITEM NUMBER	24081
MODEL	VP-CN-0971
DESCRIPTION	Double Seal Bar
SEAL BAR	16.5" x 0.31" / 42cm x 0.8cm (2x)
CYCLE TIME	23 seconds
PUMP POWER	20 m ³ /h
POWER	0.9 kW / 1.2 HP
CHAMBER SIZE	17.3" x 16.5" x 3" / 44cm x 42cm x 7.3cm (5" / 13 cm with dome cover)
ELECTRICAL	220V / 60 / 1
WEIGHT	176 lbs. / 79.8kg.
DIMENSIONS(DWH)	22" x 18.7" x 39" / 56cm x 47cm x 99cm

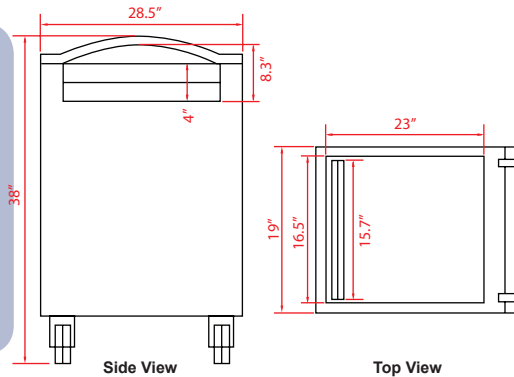

1.2 HP and 15.7" Single Seal Bar - 23" x 16.5" x 4"

ITEM NUMBER	24082
MODEL	VP-CN-1220
DESCRIPTION	Single Seal Bar
SEAL BAR	15.7" x 0.31" / 40cm x 0.8cm
CYCLE TIME	26 seconds
PUMP POWER	20 m ³ /h
POWER	0.9 kW / 1.2 HP
CHAMBER SIZE	23" x 16.5" x 4" / 58cm x 42cm x 10cm (8.3" / 21cm with dome cover)
ELECTRICAL	110V / 60 / 1
WEIGHT	200.75 lbs. / 91kg.
DIMENSIONS(DWH)	28.5" x 19" x 38" / 72cm x 48cm x 97cm

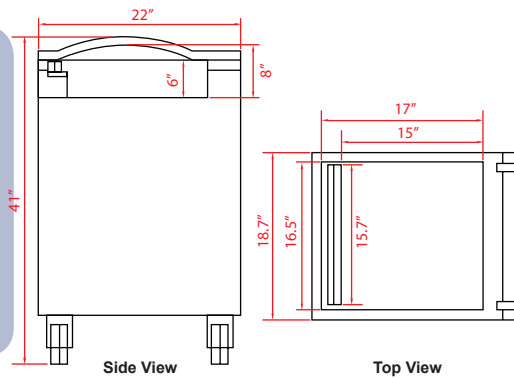

1.2 HP and 15.7" Single Seal Bar - 17" x 16.5" x 6"

ITEM NUMBER	24083
MODEL	VP-CN-1060
DESCRIPTION	Single Seal Bar
SEAL BAR	15.7" x 0.31" / 40cm x 0.8cm
CYCLE TIME	25 seconds
PUMP POWER	20 m ³ /h
POWER	0.9 kW / 1.2 HP
CHAMBER SIZE	17" x 16.5" x 6" / 43cm x 42cm x 15cm (8" / 20cm with dome cover)
ELECTRICAL	110V / 60 / 1
WEIGHT	187 lbs. / 84.8kgs
DIMENSIONS(DWH)	22" x 18.7" x 41" / 56cm x 47.5cm x 104cm

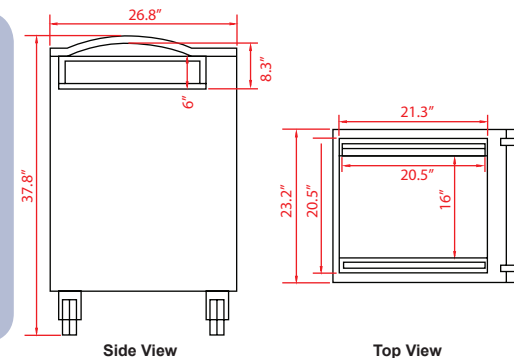

Heavy-duty 14.75 HP and 19" Double Seal Bar - 21.3" x 20.5" x 6"

ITEM NUMBER	31824
MODEL	VP-CN-1273
DESCRIPTION	Double Seal Bar
SEAL BAR	20.5" x 0.31" / 52cm x 0.8cm (2x)
CYCLE TIME	28 seconds
PUMP POWER	45 m ³ /h
POWER	1.1 kW / 1.4 HP
CHAMBER SIZE	21.3" x 20.5" x 6" / 54cm x 52cm x 15cm (8.3" / 21cm with dome cover)
ELECTRICAL	220 V / 60 Hz / 3 Ph
WEIGHT	253 lbs. / 114.8kg.
DIMENSIONS(DWH)	26.8" x 23.2" x 37.8" / 68cm x 59cm x 96cm

Item 31824 Plug and Wire (not included): Requires a certified electrician to install unit.

OMCAN INC.

Telephone: 1-800-465-0234

Fax: (905) 607-0234

E-mail: sales@omcan.com

Website: www.omcan.com



Follow us to keep up to date with the latest news and offers

